

# **GME Response to Proposed Changes in USMLE Exam Schedule**

Lois L. Bready, M.D.  
Associate Dean for Graduate Medical  
Education  
UTHSC San Antonio

### Roles that influence my view:

- DIO - Designated Institutional Official
- GME Committee
- AAMC Group on Resident Affairs
- Anesthesiology RRC
- Former residency program director

# *GME Response*

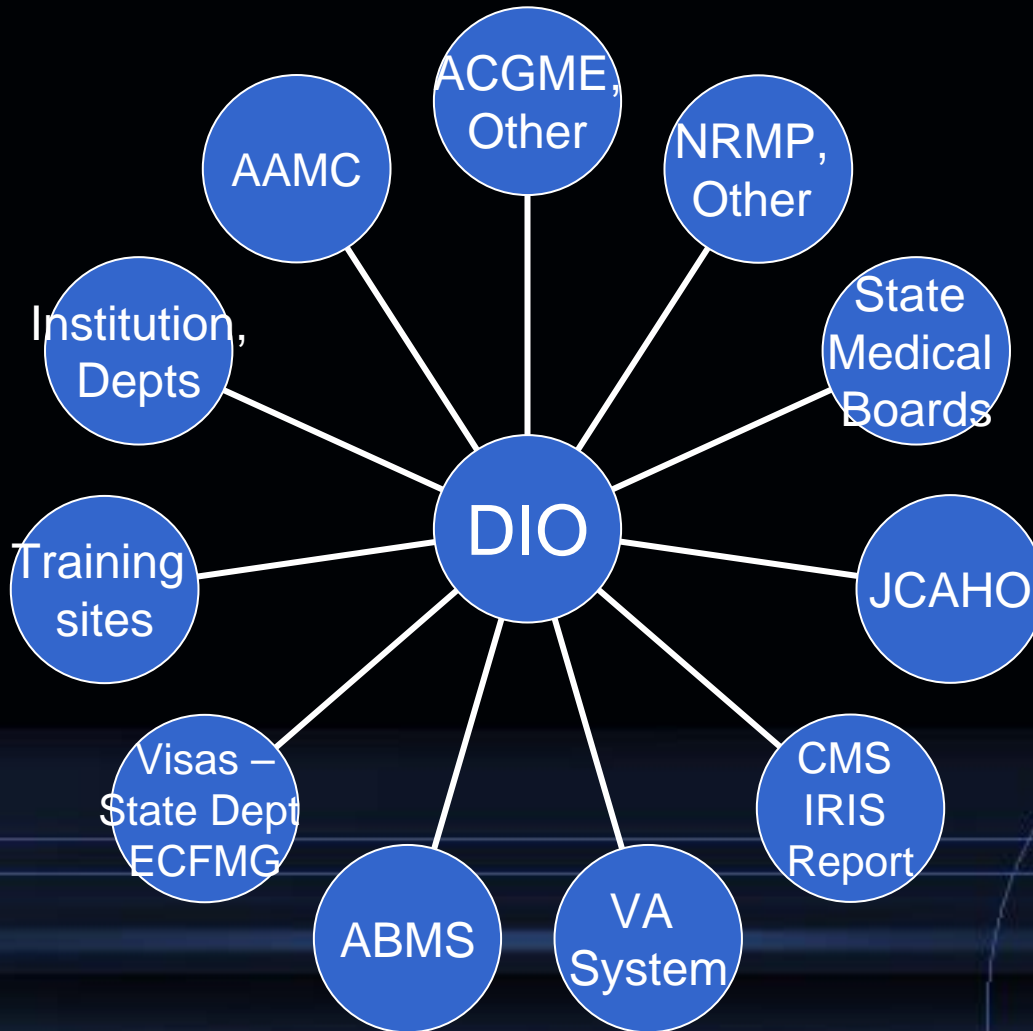

### Data that influences my view:

- San Antonio program directors – 1/08 query
- Input - AAMC GRA members, their PDs – 2/08
- Responses to survey – ACGME Town Hall Meeting 3/2/08

### Feedback from GME:

- Focused and consistent
- Not supportive of proposed changes (timing, scoring)

# GME Response

## GME Timeline

Neurosurgery, Ophthalmology,  
Urology – match in January

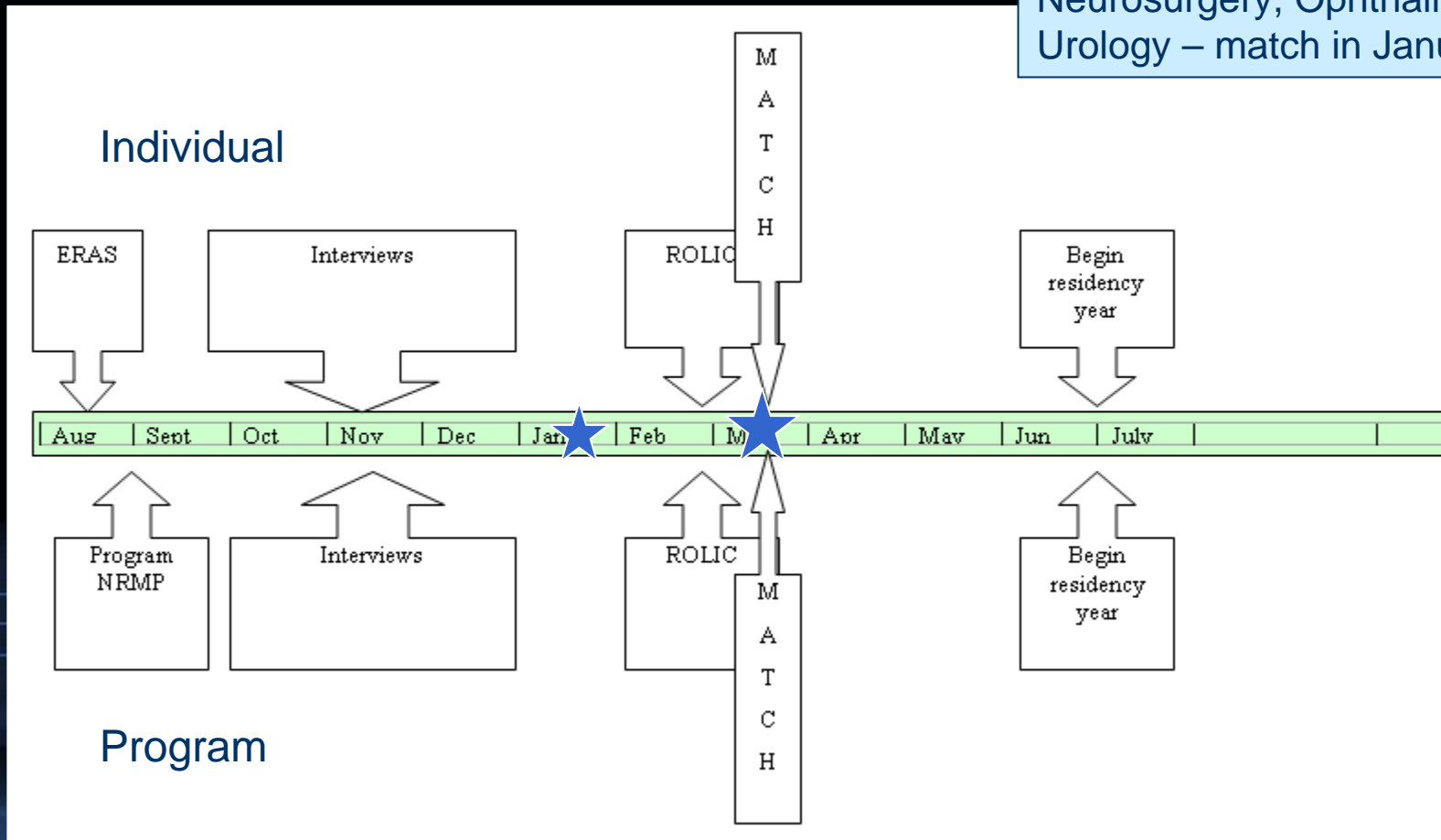

### GME process begins early fall - MS4 year

- Applications
  - NRMP opens 8/15 for applicants, 9/1 for programs
  - San Francisco & Urology matches – earlier
- Range of applicants/available position
  - Several to hundred
  - Finite number of interview slots
  - Labor and time intensive

### GME process – Who to interview?

- Hundreds-thousands of applicants to program
- Unknown school/international graduates
- Appropriate and legal discrimination permissible
  - Likely to succeed and thrive in my program
  - Likely to pass board exams
    - Affect accreditation status of program, institution
- ERAS – set filters for USMLE step scores

## GME process – Who to interview?

- Components of application
  - Personal statement, demographics
  - Dean's letter
  - Transcript
  - Letters of recommendation
  - USMLE score(s)\*

\* Only objective, normed, validated numerical scores available to programs to assist in the process of screening applicants for interviews.

## GME process – Who to interview?

- Program-specific processes
- More competitive specialties – set filters higher

### GME process – How to rank?

- Program-specific processes
- USMLE scores – one of many elements
  - Good scores may not correlate well with outcome as resident
  - Poor scores/multiple attempts do predict a struggle through the residency

### GME process – able to begin program?

- Criterion for graduation
  - Delay graduation
  - Can't start July 1
  - NRMP not binding
- Eligibility for state medical training license
- Disruptive to individual and program

GME process – able to complete program?

- Criterion for continuing state medical training license
- State licensure necessary for board certification

### Current exam - what features are important to GME?

- Normed, validated exam
- Numerical score, not P/F
- Timing – scores available by 9/1-9/15
- If single exam, early enough to remediate if needed, allow on-time graduation
- No increase cost to students
- No/minimal additional time/travel required

Visioning future exam(s) – what would be important to GME?

- Competencies needed to enter residency training
  - Medical knowledge – addressed in written exam
  - Patient care
  - Interpersonal & communication skills – CS exam
  - Professionalism
  - Systems based practice
  - Practice based learning & improvement
  - (Procedural competence)

# GME Response

Competency	Pers State	Dean's ltr	Transcript	Ltrs of rec	USMLE
Med knowledge			+/-		<input checked="" type="checkbox"/>
Patient care		+/-			
Interpersonal & Comm Skills		+/-			<input checked="" type="checkbox"/> CS
Professionalism	+/-	+/-			
Systems Based Practice					
PBLI					
(Procedural)		+/-			

# GME Response

## GME Timeline

Neurosurgery, Ophthalmology,  
Urology – match in January

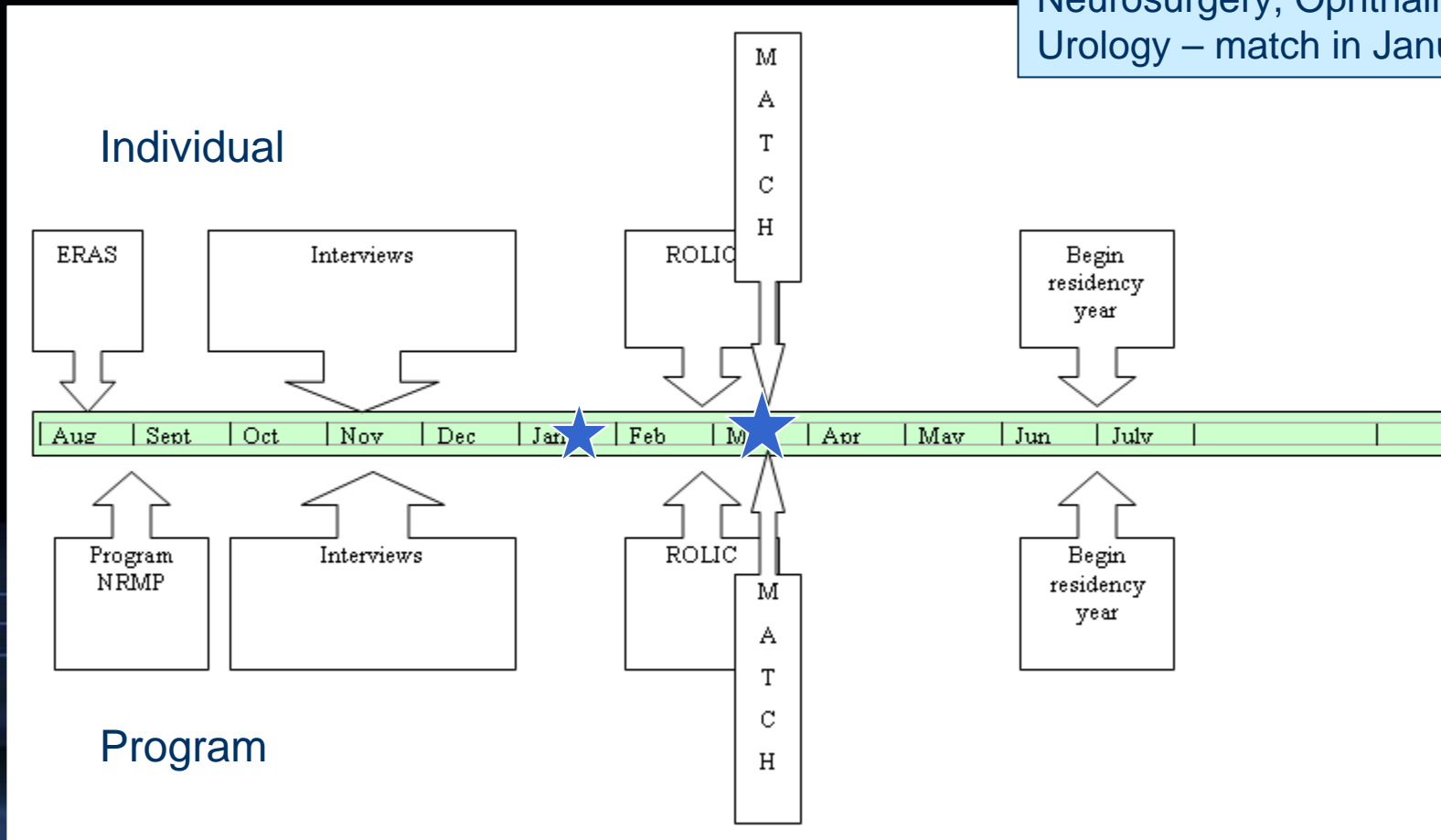

- Discussion